

BALER SUPERPEGGY

The baler SUPERPEGGY is characterized by **compacted dimensions** and operating flexibility. SUPERPEGGY is, in fact, equipped with a **system to adjust the bale weight and dimensions** allowing to select preferred options between three different heights in order to set the required weight. Moreover, the baler can be used to collect **paper and cardboard or plastic material and packaging**.

The **fully-loaded indicator** guarantees to the operator to work safely and to detect immediately when the machine is full. The packaging process is simple, thanks to a system specifically designed and installed on the machine.

SUPERPEGGY is the ideal solution for limited areas where the compacted material has to be moved manually.

1. SUPERPEGGY can be used for compaction of paper, cardboard, plastic or packaging material.
2. Once the compaction is completed, the bale extraction is simple and comfortable.
3. The control panel is equipped with visual intuitive instructions and easy to understand.
4. The belt position allows an easy replacement.



SUPERLIZZY

Making space for nature!

BALER SUPERPEGGY

Depth	785 mm
Width	765 mm
Height	1428 mm
Voltage feeding	208/230 (V) single phase (+/-10%)
Frequency	50 Hz
Installed power	Connection with Schuko plug 16 Amp 2500 W
Weight	300 Kg
Bale dimensions	600 L x 400 P x 350 H mm

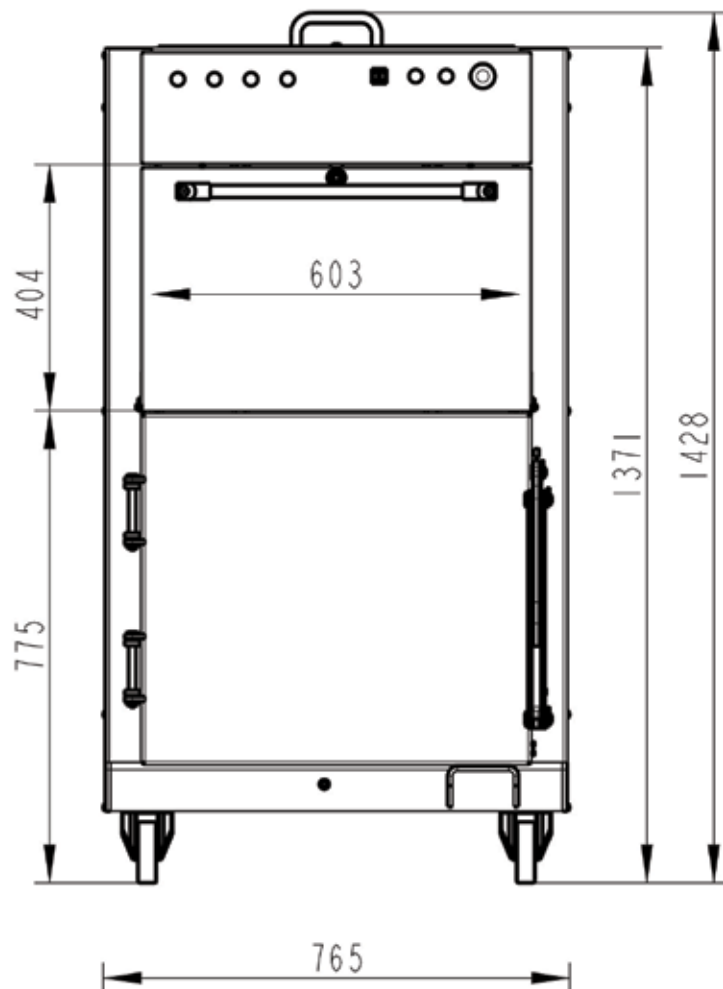
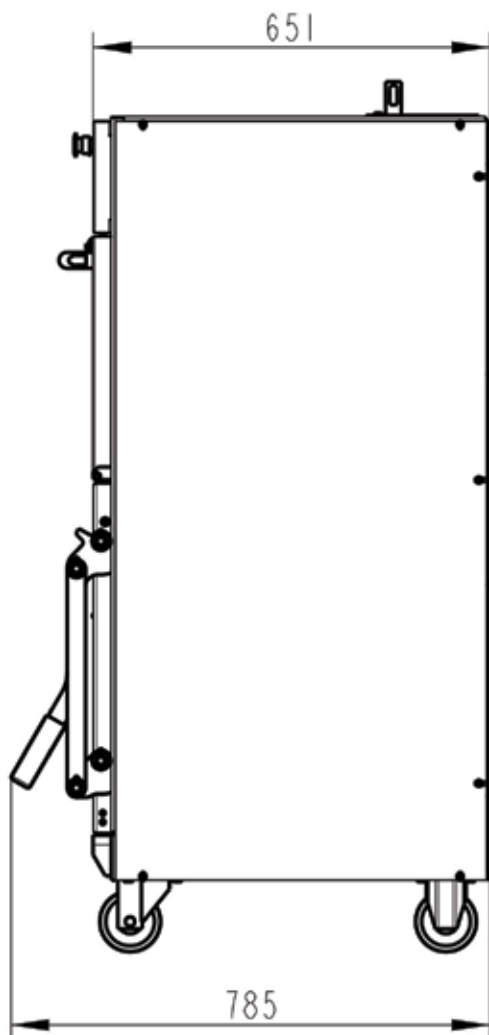
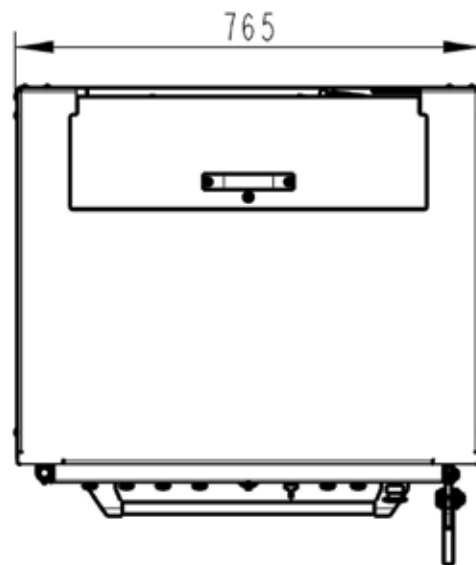

All CO.MA.RI. equipment comply with CE machine rules about safety (89/392/CEE, amended by 91/368/CEE, 93/44/CEE and 93/68/CEE)



Glanco.

Fumbally Exchange, Bricklane,
The Viking Triangle,
Waterford, Ireland
Tel: +353 876 848 449 | Email: info@glanco.ie
www.glanco.com